

PMC-1001FH



PMC-1001FH

Standard SMD Reed Switch

Electrical Characteristics

@ 25 °C

Contact form		A
Contact material		Ru
Contact rating max.	W / VA	10
Switching voltage max.	VDC	180
	VAC	130
Switching current max.	A	0.7
Carry current max.	A	1
Breakdown voltage min.	VDC	200
Contact resistance max. (initial)	mΩ	200
Insulation resistance min.	Ω	10 ⁹

Magnetical Characteristics (of unmodified Reed Switch)

@ 25 °C

Pull in range available	AT	10 - 25
Drop out min.	AT	4
Test coil	TC	010
Test equipment tolerance	±AT	2

Operating Characteristics

@ 25 °C

Switching frequency max.	Hz	500
Resonant frequency typ.	Hz	5000
Operate time max. (incl. bounce)	ms	0.5
Release time max.	ms	0.3

Environmental Characteristics

Operating temperature	°C	-40 to +125
Storage temperature	°C	-40 to +60
Soldering temperature max.	°C	255
Vibration (50-2000 Hz)	g	20
Shock (1/2 sin 11 ms)	g	100
Lead tensile strength min.	kg	3

Features

- Small size
- Zero power consumption
- Not ESD sensitive
- Over 1 billion reliable operations at dry circuits or low level loads
- Perfect economical alternative to Hall switches
- Tape & reel packaging
- Suitable for automated assembly

Approvals



Dimensions in mm

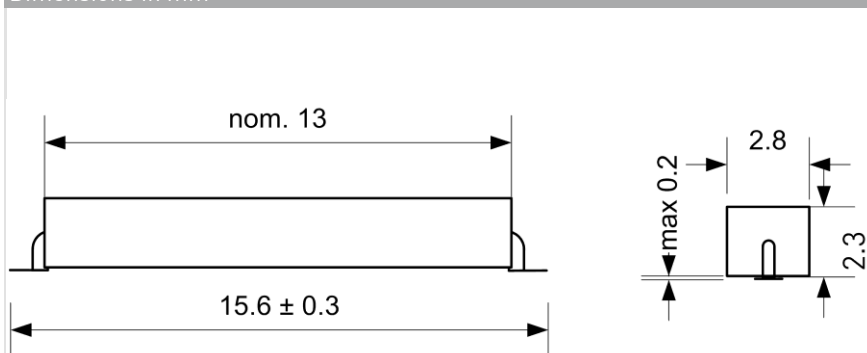

Position of contact blades not defined.

Ordering Information

Packing Unit	2500 pcs
Weight per piece	0.2 g
Weight per package	1050 g
Reel size	13 inches
Standard AT ranges	

- 10 to 15 AT
- 15 to 20 AT
- 20 to 25 AT

Ordering example

PMC1001FH1015 describes PMC-1001FH with 10-15 AT.

PMC-1001FH



PMC-1001FH
Standard SMD Reed Switch

Recommended PCB Layout in mm

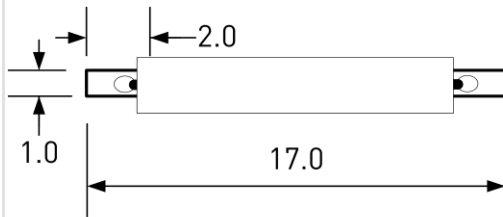

Pad sizes

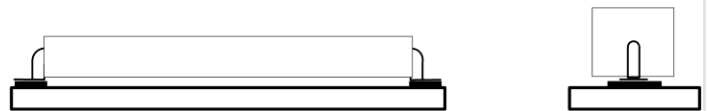

Final assembly position

Soldering Information

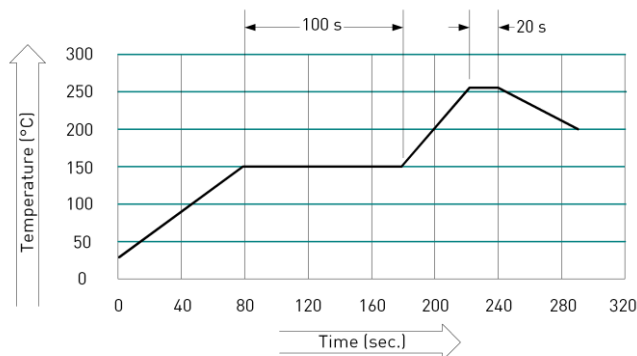

Mounting Force

Recommended Mounting Force	3 N
Maximum Mounting Force	8 N

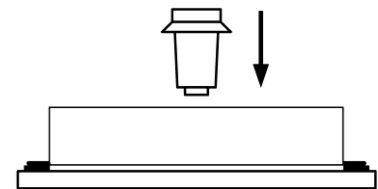

Tape Dimensions in mm

Tolerance ± 0.1 unless otherwise specified

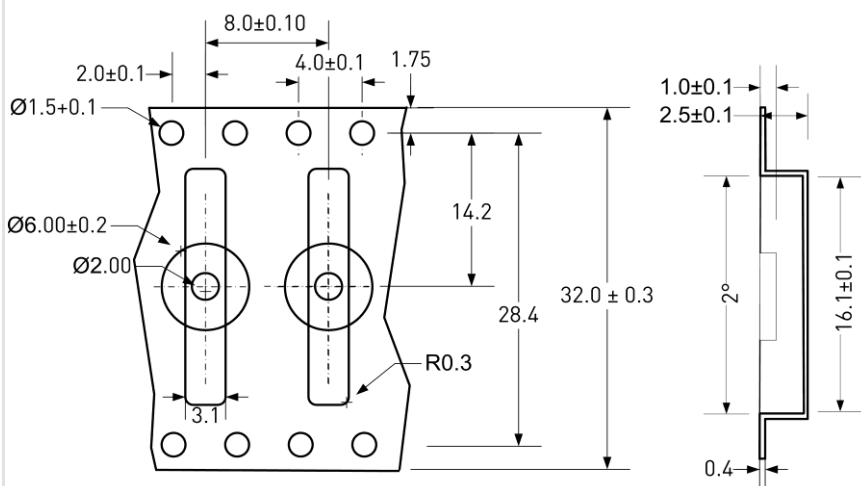

Remarks

When placed onto ferromagnetic parts switching distance of PMC-1001FH may reduce.

Electromagnetical influences and magnetic fields may change the switching behaviour of the SMD Reed Switch.