

HS-324-03-0300

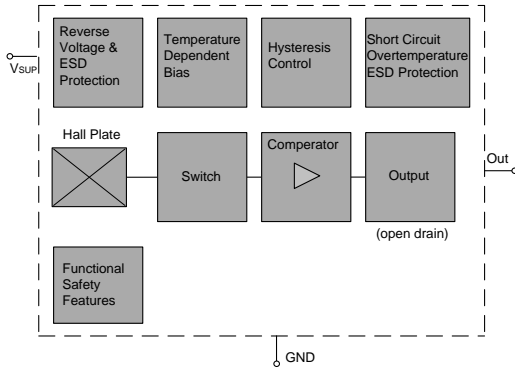

Product image serves as example only.

Block Diagram



HS-324R-03-0300

Unipolar 3 - Wire
Flatpack Hall Effect Sensor

Features

- > Compact size
- > Various switching sensitivities
- > Various switching points available
- > Customized types available

Approvals



Absolute Maximum Ratings

Stresses beyond those listed in the "Absolute Maximum Ratings" may cause permanent damage to the device
Functional operation of the device at these conditions is not implied. Exposure to the absolute rating conditions for extended periods will affect device reliability

Symbol	Parameter	wire colour	Min.	Max.	Unit	Conditions
V _{SUP}	Supply voltage	red	- 18		V	t < 1000 h ¹⁾
			-	28	V	t < 96 h ¹⁾
			-	32	V	t < 5 min ¹⁾
			-	40	V	t < 5 x 400 ms ¹⁾ with series resistor R _V > 100 Ohm
V _{OUT}	Output voltage	white	- 0.5		V	t < 1000 h ¹⁾
			-	28	V	t < 96 h ¹⁾
			-	32	V	t < 5 min ¹⁾
			-	40	V	t < 5 x 400 ms ¹⁾ with series resistor R _V > 100 Ohm
I _O	Output current	white	-	65	mA	
I _{OR}	Reverse output current	white	- 50		mA	

¹⁾ No cumulative stress All voltages listed are referenced to ground (GND)

Dimensions

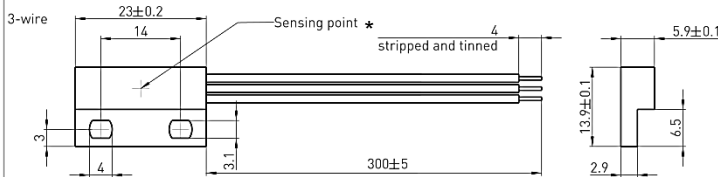

* other positions on request

Wire Assignment

Name	Function	Cable colour
VSUP	Supply voltage	red
OUT	Output	white
GND	Ground	black

HS-324R-03-0300
└─ wire length [mm]

Material Information

	Material	Colour
Housing	ABS	black
Cable	UL1007/1569, AWG 24	red, white, black
Potting compound	Epoxy	black

Environmental Characteristics

Operating temperature	°C	- 20 to + 85
-----------------------	----	--------------

HS-324-03-0300

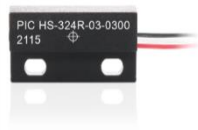

HS-324R-03-0300

Unipolar 3 - Wire
Flatpack Hall Effect Sensor

Characteristics

At recommended operation conditions if not otherwise specified in the column "Conditions".

Typical characteristics for $T_J = 25\text{ }^\circ\text{C}$ and $V_{SUP} = 12\text{ V}$

Symbol	Parameter	wire colour	Min.	Typ.	Max.	Unit	Conditions
Supply							
I_{SUP}	Supply current	red		1.6	2.4	mA	
I_{SUPHi}	Reverse current				1	mA	for $V_{SUP} = -18\text{ V}$
Output							
V_{ol}	Port low output voltage	white		0.13	0.4	V	$I_o = 20\text{ mA}$
					0.5	V	$I_o = 25\text{ mA}$
t_f	Output fall time ¹⁾				1	μs	¹⁾ $V_{SUP} = 12\text{ V};$
t_r	Output rise time				1	μs	$R_L = 820; C_L = 20\text{ pF}$
t_d	Delay time ¹⁾			16		μs	
t_{smp}	Output refresh period		1.6	2	2.66	μs	
t_{en}	Enable time of output after settling of V_{SUP}			50		μs	$V_{SUP} = 12\text{ V}$ $B > B_{on} + 2\text{ mT}$ or $B < B_{off} - 2\text{ mT}$
Power-on-self-test							
Self test can be triggered externally; details on request							
¹⁾ Guaranteed by design							

Recommended Operating Conditions

Symbol	Parameter	wire colour	Min.	Max.	Unit	Conditions
V_{SUP}	Supply voltage	red	2.7	24	V	
V_{OUT}	Output voltage	white		24	V	
I_{OUT}	Output current	white		25	mA	

HS-324-03-0300

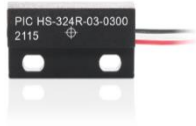

HS-324R-03-0300

Unipolar 3 - Wire
Flatpack Hall Effect Sensor

Magnetic Characteristics Overview

Symbol	Parameter	wire colour	Min.	Typ.	Max.	Unit	Conditions
B_{ONth}	ON threshold range ¹⁾	-	- 30		30	mT	
B_{OOth}	OFF threshold range ¹⁾	-	- 30		30	mT	
B_{th}	Adjustable step size ²⁾	-		0.5		mT	
T_c	Temperatur compensation of magnetic thresholds ³⁾	-	0		- 3000	ppm/K	

¹⁾ Available range

²⁾ Small steps at small values, bigger steps at higher values. May not be undercut

³⁾ Different temperature compensation available on request

Magnetic Characteristics

Switching Type	Temp. koeff. of magnetic thresh. TC [ppm/K]	On point B_{ON}			Off point B_{OFF}			Hysteresis B_{HYS} ¹⁾		
		[mT]			[mT]			[mT]		
		Min.	Typ.	Max.	Min.	Typ.	Max.	Min.	Typ.	Max.
unipolar	-1000	3.8 A	5.5 B	7.1 C	2.1 D	3.7 E	5.5 F	-	1.8	-

¹⁾ The hysteresis is the difference between the switching points $B_{HYS} = B_{ON} - B_{OFF}$

Magnetic Approach (for example)

unipolar type

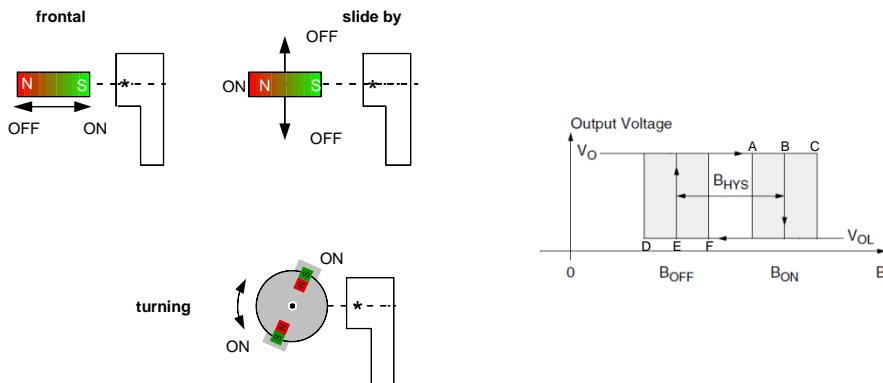

★ Sensing point