

MS-228M-3





MS-228M-3

Reed Sensor M8 metal thread

Electrical Characteristics		@ 25 °
Contact form		A
Contact rating max.	W / VA	10
Switching voltage max.	VDC	200
	VAC	140
Switching current max.	A	1
Carry current max.	A	1.2
Breakdown voltage min.	VDC	240
Total resistance max. (initial)	mΩ	300
Insulation resistance min.	Ω	10 ¹⁰

Features
> Adjustable switching point
> Metal housing with M8 thread
> Mechanically protected
> Various sensitivity ranges available

Magnetical Characteristics (of unmodified Reed Switch)		@ 25 °
Pull in range available	AT	10 - 25
Drop out min.	AT	4
Test coil	TC	014
Test equipment tolerance	± AT	2

Approvals



Contact PIC for Agency Ratings!

Operating Characteristics (of unmodified Reed Switch)		@ 25 °
Switching frequency max.	Hz	500
Resonant frequency typ.	Hz	4000
Operate time max. (incl. bounce)	ms	1
Release time max.	ms	0.4

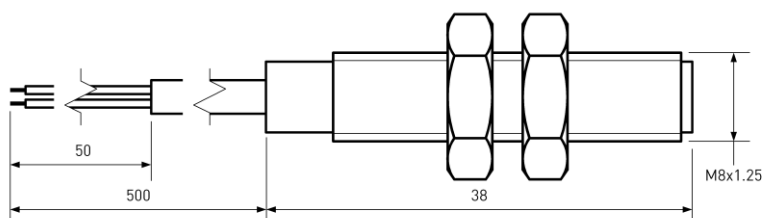
Environmental Characteristics		
Operating temperature	°C	-20 to +85
Vibration (50-2000 Hz)	g	20
Shock (1/2 sin 11 ms)	g	100

Dimensions in mm



Ordering Information	
Packing Unit	25 pcs
Weight per piece	22.5 g
Weight per package	580 g
Standard AT Ranges	
	1 = 10 to 15 AT
	2 = 15 to 20 AT
	3 = 20 to 25 AT

Ordering Example
MS-228M-3-2 describes MS-228M-3 with 15 to 20 AT.

MS-228M-3



MS-228M-3

Reed Sensor M8 metal thread

Material Information

	Material	Colour
Housing	Brass, Nickel plated	
Cable	UL 2464, AWG 24, 50 mm dismantled, 4 mm stripped and tinned	Jacket: black, wires: black and red
Potting compound	Epoxy	black
Nuts	Brass, Nickel plated, M8, 2 pcs separately packed	

Test Procedure of final Reed Sensor

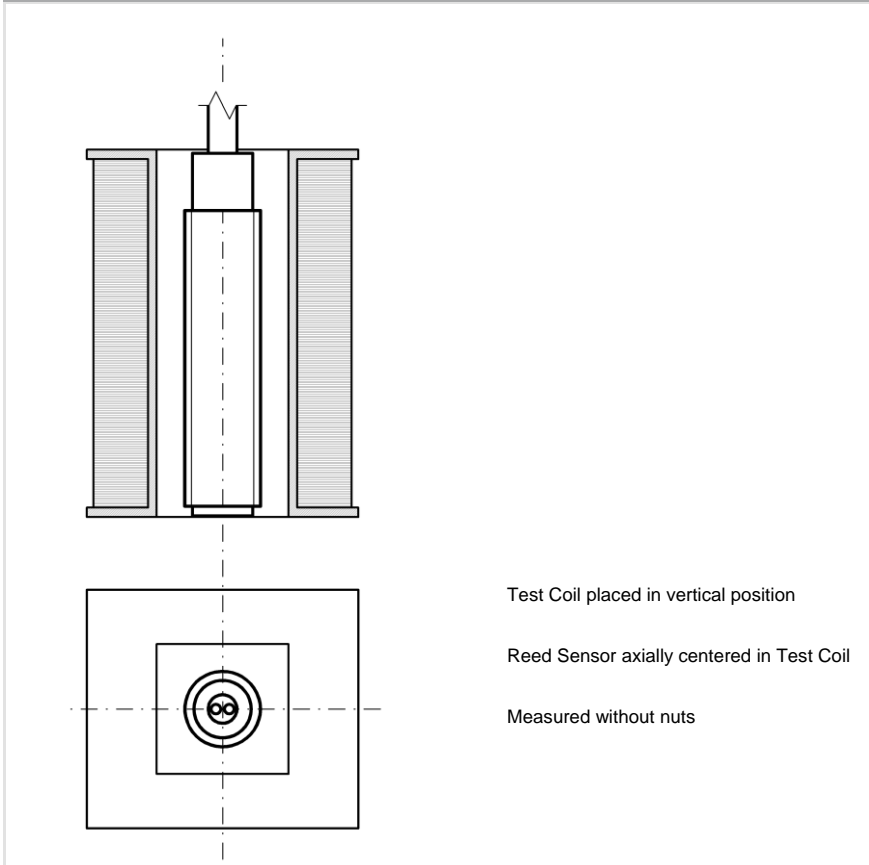

Test Parameters

Test coil	TC- 324
Test programs	
AT range	Test program
1 =	MS-228M-3- 1
2 =	MS-228M-3- 2
3 =	MS-228M-3- 3

Remarks

When mounted onto ferromagnetic parts switching distance of MS-228M-3 may reduce. Electromagnetical influences and magnetic fields may change the switching behaviour of the sensor.

Matching actuator MSM-228M available as well.